

Host range and local parasite adaptation

Marc J. Lajeunesse and Mark R. Forbes*

Department of Biology, Carleton University, 1125 Colonel By Drive, Ottawa, ON, Canada K1S 5B6

Parasites may be expected to become locally adapted to their hosts. However, while many empirical studies have demonstrated local parasite adaptation, others have failed to demonstrate it, or have shown local parasite maladaptation. Researchers have suggested that gene flow can swamp local parasite–host dynamics and produce local adaptation only at certain geographical scales; others have argued that evolutionary lags can account for both null and maladaptive results. In this paper, we use item response theory (IRT) to test whether host range influences the likelihood of parasites locally adapting to their hosts. We collated 32 independent experiments testing for local adaptation, where parasites could be assigned as having either broad or narrow host ranges (BHR and NHR, respectively). Twenty-five tests based on BHR parasites had a significantly lower average effect size than seven NHR tests, indicating that studies based on BHR parasites are less likely to demonstrate local parasite adaptation. We argue that this may relate to evolutionary lags during diffuse coevolution of BHR parasites with their hosts, rather than differences in experimental approaches or other confounds between BHR and NHR studies.

Keywords: host range; item response theory; local adaptation; meta-analysis; parasites

1. INTRODUCTION

Parasites may be expected to become adapted to their local hosts, because parasites are often more numerous and have shorter generation times than their hosts (Hamilton *et al.* 1990; Ebert 1994; Ebert & Hamilton 1996; Imhoof & Schmid-Hempel 1998). Thus, parasites should evolve faster than hosts in ways to increase their fitness at the expense of local hosts. Although parasite local adaptation is common, many studies fail to demonstrate it (Strauss 1997; Koskela *et al.* 2000), whereas others detect local parasite maladaptation (Kaltz *et al.* 1999; Oppliger *et al.* 1999). Some researchers have thus concluded that parasite local adaptation occurs only on average (see Kaltz & Shykoff 1998; Van Zandt & Mopper 1998). Recently, Lively (1999) suggested that short generation times of parasites are neither necessary nor sufficient for local adaptation. It is known that some parasites are not locally adapted despite having much shorter generation times than their hosts (Memmott *et al.* 1995; Kimberling & Price 1996; Alstad 1998).

Collectively, these studies suggest that other aspects of parasite natural history may be important determinants of local adaptation. Evolutionary lags between parasite genotypes tracking host genotypes may account for some parasites being able to exploit allopatric hosts better than sympatric hosts (Morand *et al.* 1996). Additionally, migration events may swamp local parasite–host dynamics (Ebert 1994; Gandon *et al.* 1996; Lively 1999; Nuismer *et al.* 1999), such that parasite adaptation is evident only at particular geographical scales (Hanks & Denno 1994; Imhoof & Schmid-Hempel 1998). However, comparative migration data across diverse parasite–host associations are scant, making it difficult to test for the effects of gene flow.

Another possible predictor is host range or the number

of host species exploited by the parasite. Documenting host range and/or the degree to which particular host species are exploited requires detailed field investigation or published accounts. For instance, the hen flea (*Ceratophyllus gallinae*) is known to parasitize at least 75 bird species (Tripet & Richner 1997; table 1). Our contention is that exposure to several host species may weaken species-specific selection, such that the parasite's ability to adapt to any particular host is depressed (both at the population and at the species level). For parasites with broad host ranges (BHR) (such as the hen flea), various hosts species might influence the coevolutionary trajectory (and lags) of the parasite. As such, host range would make the exhibition of local adaptation difficult or non-apparent at certain scales (Gomulkiewicz *et al.* 2000), or problematic when non-tracked hosts are chosen for experimentation. We hypothesize that host range variation contributes to the disparity of results for tests of local adaptation.

To explore this, we compare strengths of differences in fitness for local and non-local parasites from transplant experiments, for parasites differing in host range. We also consider different types of parasite–host associations (plants and plant pathogens, invertebrates and their parasites, etc). Transplant experimentation is the most common method for comparing 'performance' of parasites (infectivity or within-host growth rate and survival) on local and non-local hosts, usually from different host populations (Kaltz & Shykoff 1998; Van Zandt & Mopper 1998). This study provides, to our knowledge, the first general test of whether host range relates to local adaptation, using analyses based on item response theory (IRT). We show that parasites with a few to several well-documented hosts (to many such hosts) are less likely to support local adaptation than parasites with principally one well-documented host, most probably because such parasites enter into diffuse coevolutionary interactions. Such findings have implications for studies on predicted impacts of parasitic or disease organisms on existing and novel hosts.

*Author for correspondence (mforbes@ccs.carleton.ca).

Table 1. Local adaptation studies in host–parasite systems.

(Presented is information on the total number of known hosts (host range) and sample sizes (n^S and n^A , sympatric and allopatric respectively). Also presented is whether the study showed the parasite to be locally adapted (1), maladapted (–1), or showed no effect (0). Common garden experiments were either done (y) or not done (n). The type of experiment is also listed as coded in figure 1. Finally, the source for each experiment is provided.)

parasite species	host species	host range	n^S	n^A	study results	common garden	study design	source
pathogens and plants								
<i>Melampsora lini</i>	<i>Linum marginale</i>	min 5	16	20	1	y	a	Burdon & Thompson (1995)
<i>Microbotryum violaceum</i>	<i>Silene dioica</i>	min 200 ^a	111	354	0	n	a ^j	Carlsson-Granér (1997)
	<i>S. latifolia</i>	min 200 ^a	14	14	–1	y	a ^j	Kaltz <i>et al.</i> (1999)
<i>Puccinia podophylli</i>	<i>Podophyllum peltatum</i>	1	102	204	0	n	a	Parker (1989)
<i>Septoria tritici</i>	<i>Triticum aestivum</i>	min 10	30	40	1	y	a ^j	Ahmed <i>et al.</i> (1995)
<i>Synchytrium decipiens</i>	<i>Amphicarpaea bracteata</i>	1	13	11	1	y	b	Parker (1985)
herbivores and plants								
<i>Altica subplicata</i>	<i>Salix cordata</i>	6	9	9	0	y	a	Milanowski & Bach (1994)
<i>Apterothrips secticornis</i>	<i>Erigeron glaucus</i>	1	30	60	1	y	a	Karban (1989)
<i>Asphondylia borrichiae</i>	<i>Borrichia frutescens</i>	1 ^b	100	180	1	n	a	Stiling & Rossi (1998)
<i>Blepharida rhois</i>	<i>Rhus glabra</i>	3	47	166	0	n	a ^j	Strauss (1997)
<i>Cryptococcus fagisuga</i>	<i>Fagus sylvatica</i>	3	5	15	1	n	a	Wainhouse & Howell (1983)
<i>Daktulosphaira vitifoliae</i>	<i>Vitis arizonica</i>	7 ^c	6	66	0	y	a ^j	Kimberling & Price (1996)
<i>Matsucoccus acalyptus</i>	<i>Pinus edulis</i>	min 5	45	90	0	y	a	Cobb & Whitham (1998)
	<i>P. monophylla</i>	min 5	50	50	0	y	c	Unruh & Luck (1987)
<i>Nuculaspis californica</i>	<i>Pinus ponderosa</i>	11 ^d	20	80	0	y	a	Alstad (1998)
<i>Pseudaulacaspis pentagona</i>	<i>Morus alba</i>	100 ^e	240	240	1	y	a	Hanks & Denno (1994)
<i>Stator limbatus</i>	<i>Acacia greggii</i>	min 50	56	53	–1	y	b	Fox <i>et al.</i> (1994)
	<i>Cercidium floridum</i>	min 50	57	55	1	y	b	Fox <i>et al.</i> (1994)
<i>Stilbosis quadricustatella</i>	<i>Quercus geminata</i>	2	120	200	1	n	a	Mopper <i>et al.</i> (1995)
plant-parasites and plants								
<i>Cuscuta europaea</i>	<i>Urtica dioica</i>	min 102	71	246	0	y	a	Koskela <i>et al.</i> (2000)
<i>Rhinanthus serotinus</i>	<i>Agrostis capillaris</i>	min 50	43	130	0	y	a	Mutikainen <i>et al.</i> (2000)
parasites and invertebrates								
<i>Aphidius ervi</i>	<i>Acyrtosiphon pisum</i>	3 ^f	30	90	0	y	a	Hufbauer & Via (1999)
<i>Crithidia bombi</i>	<i>Bombus terrestris</i>	2	6	12	0	y	a	Imhoof & Schmid-Hempel (1998)
<i>Fasciola hepatica</i>	<i>Lymnaea truncatula</i>	min 20 ^g	420	222	–1	y	d	Gasner <i>et al.</i> (2000)
<i>Microphallus</i> sp.	<i>Potamopyrgus antipodarum</i>	2	458	956	1	y	a	Lively (1989)
	<i>Daphnia magna</i>	min 5	9	37	1	y	a ^j	Ebert (1994)
<i>Wuchereria bancrofti</i>	<i>Aedes polynesiensis</i>	min 15	58	144	1	y	b	Failloux <i>et al.</i> (1995)
parasites and vertebrates								
<i>Ceratophyllus gallinae</i>	<i>Parus major</i>	75 ^h	33	20	0	y	c	Dufva (1996)

(Continued)

2. METHODS

(a) Data collection and selection criteria

We collated information from 32 independent tests from papers published on local adaptation and references cited in review papers (Boecklen & Mopper 1998; Gandon 1998; Kaltz & Shykoff 1998; Van Zandt & Mopper 1998). Our search was exhaus-

sive, but limited to published accounts (literature searches from 1979–2001). Many papers failed to show local adaptation. In fact, there were nearly as many null as positive results (table 1), indicating that poor representation of null results did not occur. Thus, we would run into the associated ‘file drawer problem’ (Arnqvist & Wooster 1995) only if null studies based on parasites with narrow host ranges (NHR) were less likely to be pub-

Table 1. *Continued.*

parasite species	host species	host range	n^S	n^A	study results	common garden	study design	source
<i>Clamator glandarius</i>	<i>Pica pica</i>	min 10	14	21	-1	n	a	Soler & Møller (1990)
<i>Diplostomum phoxini</i>	<i>Phoxinus phoxinus</i>	4	64	65	1	y	a	Ballabeni & Ward (1993)
<i>Molothrus ater</i>	<i>Dendroica petechia</i>	216 ^d	15	15	-1	n	b	Briskie <i>et al.</i> (1992)
	<i>Turdus migratorius</i>	216 ^d	25	18	-1	n	b	Briskie <i>et al.</i> (1992)

^a Garr *et al.* (1997).

^b Found in two biotypes; one specific to *B. frutescens* and the other exclusive on two other host species (Stiling *et al.* 1999).

^c Downie *et al.* (2000).

^d Alstad (1998).

^e Hanks & Denno (1994).

^f Powell & Wright (1988).

^g Pantelouris (1965).

^h Tripet & Richner (1997).

ⁱ Friedmann *et al.* (1977).

^j Did not conduct all potential reciprocal transfers.

lished than null studies based on parasites with BHR; see Van Zandt & Mopper (1998) for similar rationales. Although less represented in the literature, negative results (local maladaptation) were also available for analysis.

We used IRT to estimate effect sizes (detailed below) rather than meta-analysis. Meta-analysis requires that a common currency is either measured or can be readily computed (see Goldberg *et al.* 1999). Metrics of parasite fitness were extremely variable among studies (e.g. parasite infection rates, growth rate, survival, spore production), and even included host-centred measures (e.g. condition, survival; cf. Mutikainen *et al.* 2000). While all measures are (thought to be) surrogates of fitness, they are not linearly equatable across studies as required by meta-analysis (Hedges & Olkin 1985). As such, measures of parasite performance were comparable only within studies. This general problem of using meta-analysis was further exacerbated by the variable reporting of means, standard deviations, and test statistics that reflected, in part, nuances of experiments, but that made computing traditional effect sizes and statistical conversions difficult (e.g. Arnqvist & Wooster 1995). We felt that many studies, where host ranges were obtainable, would have to be omitted if we used meta-analysis. Finally, IRT and meta-analysis compute similar effect sizes, based on published examples of meta-analysis, recomputed using IRT (M. J. Lajeunesse, personal observation).

To be included in our analyses, tests had to compare metrics of parasite fitness (either parasite- or host-centred) for parasites exploiting local and non-local hosts of the same species, using a transplant or reciprocal transplant experiment (figure 1). In the latter case, this would produce two local–local controls and two local–non-local experimental groups (figure 1a). Studies that compared the performance of parasites on different host species (one local and one non-local) were excluded if they did not complete the reciprocal comparison among populations of the same host species (e.g. Akimoto 1990; Via 1991). This exclusion was necessary because parasites with NHRs (see below) were not likely to be tested on different host species. Metrics of parasite fitness also had to be compared among groups, preferably in a common garden setting (i.e. all experimental treatments were exposed to similar environments; see Lively (1989); table 1), although this was not always possible for practical reasons (e.g. Briskie *et al.* 1992). Additionally, repli-

cation had to be indicated such that sample sizes for comparisons of allopatric and sympatric associations could be assigned. We also required that two-tailed tests (alpha 0.05) for parasite/host performance between sympatric and allopatric associations were reported, given null outcomes and local maladaptation were possible. Only empirical studies were included (i.e. not theoretical treatments, e.g. Kraaijeveld & Godfray 2001). Finally, we only included studies if parasites could be assigned a host range (e.g. excluding studies like Oppliger *et al.* (1999)). Host range was assigned by detailed literature searches; we did not rely on labels such as ‘specialists’ or ‘generalists’.

Parasites with a NHR were those that have a single well-documented host species, or a single host species at the stage of their life cycle being studied (i.e. for macrocyclic trematodes, fungi, etc.). In some cases, there were reports of anecdotal associations between parasites and novel hosts (i.e. hosts not normally encountered in nature). We treated these as NHR parasites (albeit described as having two hosts; table 1), while recognizing that such unnatural associations would also occur for parasites with BHR. Parasites with BHR had at least three (and most often many more) well-documented hosts for the life stage being considered (table 1). This classification of NHR and BHR parasites may seem somewhat artificial because NHR parasites in our study may be shown to have more hosts through more detailed parasitological work. Likewise, BHR parasites may have rather narrow host ranges over much of their geographical range, and thus could be treated as NHR parasites should this degree of spatial variation in host use become available. However, we do feel that this classification reflects the degree to which parasites considered herein enter ‘diffused’ coevolutionary relationships with hosts. Finally, we treated results for different host–parasite associations as independent, even if either the host or the parasite was shared with another association; see Poulin (1996) and Schalk & Forbes (1997) for similar rationale(s).

(b) Analyses

To estimate effect size for NHR and BHR studies, we used IRT (Lord 1980; van der Linden & Hambleton 1997; Appendix A). In this study, a data point (k) resulted from a two-tailed test (or multiple tests) for differences in parasite performance on sympatric versus allopatric hosts. Data points were scored as

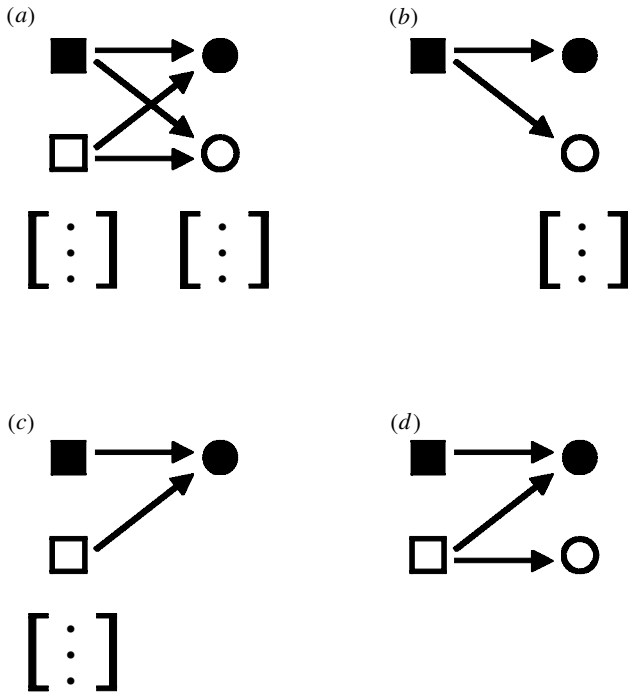

Figure 1. The various types of transplant experiments used in testing for parasite local adaptation. In (a), two parasite populations (represented by black and white squares) are crossed to two host populations (represented by black and white circles). The colour of the square or circle denotes the location of the parasite or host population. Therefore in (a), there are two allopatric (experimental) and two sympatric (control) combinations of parasites infecting hosts. Experimental types (b–d) are various permutations of type (a). Many more such combinations could be envisioned and have been tested (e.g. where more than two parasite populations are crossed with more than two host populations, which could be represented by more colours, but shown here as [:]).

either ‘0’ if there was no significant difference in parasite performance on local versus non-local hosts, ‘1’ if there was significant effect indicating parasite local adaptation, or ‘–1’ if parasites showed local maladaptation (see table 1). We scored a study’s research outcome by evaluating whether all tests showing significance in a particular direction (either towards local adaptation or maladaptation) were not attributable by chance, after adjusting for the total number of tests examined in that particular study using binomial expansion (see Appendix A). Here, the probability that such results could be due to chance decreased as the number of significant test results increased. No study showed evidence for local adaptation on one metric and evidence for local maladaptation on another. Studies showing no effects on all metrics were categorized as null studies. While this approach biases towards concluding local adaptation, we note that that it should not be more likely for researchers testing NHR versus BHR parasites. As mentioned, many researchers did not conclude local adaptation and we wanted to know whether those researchers more often dealt with BHR parasites.

We further contend that the use of p -values to help score outcomes of studies is valid based on IRT (despite not being valid for typical meta-analyses; Gurevitch & Hedges 1999; Osenberg *et al.* 1999). We note that results are weighted by corrections based on sample sizes (see below), so significant results based on small samples are given low weight, avoiding the funnel prob-

lem often seen in meta-analysis. Moreover, research outcomes are not directly based on p -values, but on the relative probability that all significant tests were not due to random effects. IRT was initially developed to adjust psychometric test scores for the effects of ‘nuisance’ properties (such as liability to guessing, or question difficulty; van der Linden & Hambleton 1997). However, if the probability of answering test questions correctly (influenced by their ‘difficulty’) and the responses from a testee are known, then IRT permits the estimation of that testee’s ‘ability’. We use IRT to estimate the effect (analogous to ‘ability’) of BHR and NHR studies to show local adaptation (Appendix A).

We recorded a vector of research outcomes for NHR and BHR studies (scoring method above), and assigned a ‘likelihood’ of exhibiting local adaptation to each constituent study (weighted by sample sizes and adjusted for multiple tests; Appendix A). Here, effect sizes are scale-free estimates of the average degree to which particular types of studies support local adaptation. Local maladaptation outcomes lower average responses more than null outcomes. We feel this is appropriate, as the main prediction is that parasites should do better on local hosts; if they do worse, this should be reflected in scores. In summary, this procedure allows estimation of effect sizes and confidence limits for groups of studies, where studies have polytomous outcomes and unequal sample sizes (Appendix A).

Our main test was whether BHR and NHR parasites differ in likelihood of showing local adaptation. Thus, we partitioned the dataset into NHR and BHR tests and computed effect sizes and confidence limits for these two types of studies. We then excluded certain parasite–host associations to ascertain whether any overall results might be ascribed to just one or a few types of associations. Some associations have figured prominently in tests of local adaptation (e.g. the adaptive deme formation of phytophagous insects; see Mopper & Strauss 1998).

3. RESULTS

The overall effect size did not significantly differ from zero (table 2), denoting a general likelihood of showing local adaptation for half the time, as concluded by others (cf. Kaltz & Shykoff 1998; Van Zandt & Mopper 1998). Studies based on BHR and NHR parasites differed in the degree to which they supported local adaptation (Scheffé’s contrast: $\chi^2 = 6.06$, d.f. = 1, $p = 0.014$). Specifically, studies examining BHR parasites had a negative effect significantly different from zero, while studies examining NHR parasites showed a weak positive effect (table 2). These differences were not attributable to differences in sample sizes between BHR and NHR studies ($\chi^2 = 0.46$, d.f. = 1, $p = 0.49$), nor influenced by a U-shaped trend in sample sizes versus research outcome (i.e. 1, 0, –1) ($F = 0.65$, d.f. = 2, 29, $p = 0.53$).

The difference between BHR and NHR parasites was maintained after excluding six plant–pathogen associations ($\chi^2 = 5.01$, d.f. = 1, $p = 0.025$), two plant–plant–parasite associations ($\chi^2 = 5.32$, d.f. = 1, $p = 0.021$) and five vertebrate–parasite associations ($\chi^2 = 4.76$, d.f. = 1, $p = 0.029$; table 2). The difference between NHR and BHR studies was no longer significant after excluding 13 tests on plant–herbivore associations or six tests on invertebrate–parasite associations (table 2; $\chi^2 = 2.32$, d.f. = 1, $p = 0.127$ and $\chi^2 = 2.56$, d.f. = 1, $p = 0.109$, respectively). Studies using BHR parasites were more likely to produce

Table 2. The number of independent experiments (k), estimated effect sizes and 95% confidence intervals (CI) for tests on local adaptation for parasites with narrow host ranges (NHR) or broad host ranges (BHR).

host-parasite system	k	effect size	min CI	max CI
full dataset ^a	32	-0.067	-0.198	0.063
NHR parasites	7	0.090	-0.080	0.260
BHR parasites	25	-0.259	-0.499	-0.039
excluding				
six plants and pathogens ^a				
NHR pathogens	5	0.234	-0.158	0.626
BHR pathogens	21	-0.314	-0.592	-0.036
13 plants and herbivores				
NHR herbivores	4	0.035	-0.167	0.236
BHR herbivores	15	-0.222	-0.484	0.040
two plants and plant-parasites ^a				
NHR plant-parasites	7	0.090	-0.080	0.260
BHR plant-parasites	23	-0.260	-0.505	-0.016
six invertebrates and parasites				
NHR parasites	5	0.088	-0.154	0.329
BHR parasites	21	-0.169	-0.369	-0.032
five vertebrates and parasites ^a				
NHR parasites	7	0.090	-0.080	0.260
BHR parasites	20	-0.205	-0.408	-0.002

^a NHR parasites significantly differed from BHR parasites (< 0.05).

null or negative outcomes than research based on NHR parasites, although this general result depended somewhat on the types of parasite-host associations chosen for retention in our analyses.

4. DISCUSSION

Host range appears an important predictor of local adaptation. BHR parasites (78% of 32 tests) were more likely to show 'no effect' or local maladaptation (68% of 25 tests) than NHR parasites (28.5% of seven tests). Significant differences in effect sizes between studies based on BHR and NHR parasites were obvious overall, and after excluding three of five parasite-host associations. This general result was sensitive to loss of certain well-represented parasite-host associations, such as plants and their herbivorous insects (13 tests). However, IRT has a limited ability to estimate effect size with such small samples (van der Linden & Hambleton 1997). The loss of significance when six tests based on invertebrate hosts and their parasites and pathogens were excluded is also not surprising, as this reduced sample size for NHR tests from seven to five.

Host range does have confounds. It relates to the parasite-host associations under study (e.g. all plant parasites and all vertebrate parasites have BHR). However, loss of these associations had no effect on the general result. Parsing data into phylogenetic groupings may reveal effects of evolutionary non-independence of certain taxonomic groups; but inability to properly estimate effects of small samples, coupled with deficiencies in the literature (i.e. lack of research on NHR parasites of vertebrates), prevent a thorough exploration of phylogenetic constraints on research outcomes. We also did not test whether respective BHR parasites have higher dispersal ability than NHR parasites (relative to their hosts). Nor did we test whether geographical scale is similar between studies

based on NHR versus BHR parasites, because geographical scale would itself have to be scaled for relative dispersal abilities of different parasites and their hosts.

We do contend that BHR parasites should show spatial evolutionary lags more than NHR parasites because BHR parasites undergo diffuse coevolution with multiple hosts (Futuyma & Slatkin 1983; Thompson 1994). We found that a large proportion of local adaptation studies was based on BHR parasites. Parasites with BHR appear more common than rare in nature. Progress will not be made in testing local adaptation and other coevolutionary hypotheses if these parasites continue to be treated as interacting with single species of hosts.

Future research should compare the ability of local BHR parasites on single species from two or more sites, where the suite of host species exploited differs between sites. Fitness performance on local hosts will probably depend on the suite of other potential hosts being exploited locally (further influenced by differences in local abundances). We predict that such parasites will be less likely to show high fitness on any given species locally, if confronted with a broad rather than a narrower host species pool.

Funding for this research was provided by an NSERC grant to MRF. Thanks go to Dieter Ebert, Tom Little, Yannis Michalakis, Andrew Read, and Paul Schmid-Hempel for helpful discussions with the second author on this and related topics. We would also like to thank three anonymous reviewers for their helpful comments on an earlier version of our manuscript.

APPENDIX A

Effect size was estimated using a technique in IRT known as the one-parameter normal ogive model for polytomous responses. Consider a collection of k studies testing local adaptation, each of which compare the outcomes of local 'sympatric' transplants (S) with non-local

'allopatric' transplants (A) of parasites and hosts (in a complete reciprocal transfer experiment, this would result in two sympatric and two allopatric comparisons). In such experiments, sample sizes are taken as the sum of all n for sympatric or allopatric tests (resulting in n^A and n^S , respectively; note these sample sizes can differ). For the i th study, we wish to observe whether the sample mean \bar{Y}_i^A of the allopatric group exceeds the sample mean \bar{Y}_i^S of the sympatric group (e.g. we observe whether $\bar{Y}_i^A - \bar{Y}_i^S > 0$ for each study; Hedges & Olkin 1985). If the expected effect sizes (δ_i) for each study share a common effect (that is, $\delta_1 = \dots = \delta_k = \delta$), our model implies that

$$\bar{Y}_i^A - \bar{Y}_i^S \sim \mathcal{N}\left(\delta\sigma_i, \frac{\sigma_i^2}{\tilde{n}_i}\right),$$

where σ_i is the common population standard deviation for the i th experimental group \mathcal{N} indicates that the model is based on a normal distribution and

$$\tilde{n}_i = \frac{n_i^A n_i^S}{n_i^A + n_i^S}.$$

The probability of a particular study exhibiting local parasite adaptation can be expressed as function of both effect and sample size, and thus becomes

$$\text{Prob}\{\bar{Y}_i^A - \bar{Y}_i^S > 0\} = p(\delta, \tilde{n}_i) = 1 - \Phi\left(-\sqrt{\tilde{n}_i}\delta\right),$$

where $\Phi(x)$ is the standard normal cumulative distribution function and $\sqrt{\tilde{n}_i}\delta$ is the noncentrality parameter used to estimate the sampling distribution of a particular study. Because the sample sizes are known, it should be possible to estimate δ with an outcome for each study. A research outcome, X (see below), was assigned to each study by calculating the probability of all its test(s) to exhibit local adaptation (or maladaptation), relative to the total number of tests performed. Specifically, if B number of tests were conducted in a study, then the probability of b tests showing significant evidence for a particular research outcome (either local adaptation or maladaptation) is

$$P(b) = {}_B C_b p^b q^{B-b}, \quad (\text{A } 1)$$

where ${}_B C_b$ is the binomial coefficient that expresses the number of ways b significant tests can be arranged within all the non-significant tests ($B - b$), p is the probability of a test yielding significant relations at the alpha level ($p = \alpha$), whereas q is the probability of a test showing non-significant relations ($1 - \alpha$). For example, consider a study that examined eight metrics of parasite performance on sympatric and allopatric hosts (i.e. conducted eight two-tailed t -tests), but found that only one test showed significant evidence for parasites performing better on local than non-local hosts. Then the resultant probability $P(b)$, derived from the binomial expansion (equation (A 1)), is 0.28. Because this probability was greater than α , this test result may have resulted from random chance. Thus in this case, we summarized the study as showing no evidence for local adaptation (assigning zero to X). In other words we defined

$$X_i = \begin{cases} 1 & \text{if } P(b_i) \leq 0.05 \text{ for local adaptation,} \\ 0 & \text{if } P(b_i) > 0.05, \\ -1 & \text{if } P(b_i) \leq 0.05 \text{ for local maladaptation.} \end{cases}$$

By uniting the outcomes X for each study into a response vector, we can estimate their gross effect size. However, because the effect cannot be solved explicitly in a formula, the effect size estimate must be expressed solely as a solution to a maximum likelihood equation, defined as

$$L(\delta|X_1, \dots, X_k) = \sum_{i=1}^k (X_i \log[p(\delta, \tilde{n}_i)] + (1 - X_i) \log[1 - p(\delta, \tilde{n}_i)]). \quad (\text{A } 2)$$

Because the data X_1, \dots, X_k are observed and the sample sizes are known, the likelihood $L(\delta|X_1, \dots, X_k)$ is a function of δ alone, where it can be maximized over δ to obtain a maximum likelihood estimate ($\hat{\delta}$) (Hedges & Olkin 1985; van der Linden & Hambleton 1997). Using this method for estimating an effect has the advantage that it reaches the true value of the effect as the number of studies increases (Hedges & Olkin 1985). Specifically, $\hat{\delta}$ must be obtained numerically by calculating the value of $L(\delta|X_1, \dots, X_k)$ for an array of possible δ values in equation (A 2). From this array, we selected our effect size ($\hat{\delta}$) as the estimate that gave the greatest value of likelihood. Confidence intervals were calculated using the large sample variance method derived from $\hat{\delta}$ (Hedges & Olkin 1985, p. 70).

REFERENCES

- Ahmed, H. U., Mundt, C. C. & Coakley, S. M. 1995 Host-pathogen relationship of geographically diverse isolates of *Septoria tritici* and wheat cultivars. *Plant Path.* **44**, 838–847.
- Akimoto, S. 1990 Local adaptation and host race formation of gall-forming aphids in relation to environmental heterogeneity. *Oecologia* **83**, 162–170.
- Alstad, D. 1998 Population structure and the conundrum of local adaptation. In *Genetic structure and local adaptation in natural insect populations* (ed. S. Mopper & S. Y. Strauss), pp. 3–21. New York: Chapman & Hall.
- Arnqvist, G. & Wooster, D. 1995 Meta-analysis: synthesizing research findings in ecology and evolution. *Trends Ecol. Evol.* **6**, 236–240.
- Ballabeni, P. & Ward, P. I. 1993 Local adaptation of the trematode *Diplostomum phoxinini* to the European minnow *Phoxinus phoxinus*, its second intermediate host. *Funct. Ecol.* **7**, 84–90.
- Boecklen, W. J. & Mopper, S. 1998 Local adaptation in specialist herbivores: theory and evidence. In *Genetic structure and local adaptation in natural insect populations* (ed. S. Mopper & S. Y. Strauss), pp. 64–90. New York: Chapman & Hall.
- Briskie, J. V., Sealy, S. G. & Hobson, K. A. 1992 Behavioral defenses against avian brood parasitism in sympatric and allopatric host population. *Evolution* **46**, 334–340.
- Burdon, J. J. & Thompson, J. N. 1995 Changed patterns of resistance in a population of *Linum marginale* and the rust pathogen *Melampsora lini*. *J. Ecol.* **83**, 199–206.
- Carlsson-Granér, U. 1997 Anther-smut disease in *Silene dioica*: variation in susceptibility among genotypes and populations, and patterns of disease within populations. *Evolution* **51**, 1416–1426.
- Cobb, N. S. & Whitham, T. G. 1998 Prevention of deme formation by the pinyon needle scale: problems of specializing in a dynamic system. In *Genetic structure and local adaptation in natural insect populations* (ed. S. Mopper & S. Y. Strauss), pp. 37–63. New York: Chapman & Hall.
- Downie, D. A., Granett, J. & Fisher, J. R. 2000 Distribution and abundance of leaf galling and foliar sexual morphs of

- grape phylloxera (Hemiptera: Phylloxeridae) and *Vitis* species in Central and Eastern United States. *Env. Entomol.* **29**, 979–986.
- Dufva, R. 1996 Sympatric and allopatric combination of hen fleas and great tits: a test of the local adaptation hypothesis. *J. Evol. Biol.* **9**, 505–510.
- Ebert, D. 1994 Virulence and local adaptation of a horizontally transmitted parasite. *Science* **265**, 1084–1086.
- Ebert, D. & Hamilton, W. D. 1996 Sex against virulence: the evolution of parasitic diseases. *Trends Ecol. Evol.* **11**, 79–82.
- Failloux, A. B., Raymond, M., Ung, A., Glaziou, P., Martin, P. M. V. & Pasteur, N. 1995 Variation in the vector competence of *Aedes polynesiensis* for *Wuchereria bancrofti*. *Parasitology* **111**, 19–29.
- Fox, C. W., Waddell, K. J. M. & Mousseau, T. A. 1994 Host-associated fitness variation in a seed beetle (Coleoptera: Bruchidae): evidence for local adaptation to a poor quality host. *Oecologia* **99**, 329–336.
- Friedmann, H., Kiff, L. F. & Rothstein, S. I. 1977 A further contribution to knowledge of the host relations of the parasitic cowbirds. *Smithsonian Contrib. Zool.* **235**, 1–75.
- Futuyma, D. J. & Slatkin, M. 1983 *Coevolution*. Sunderland: Sinauer Associates.
- Gandon, S. 1998 Local adaptations and host–parasite interactions. *Trends Ecol. Evol.* **13**, 214–216.
- Gandon, S., Capowiez, Y., Dubois, Y., Michalakis, Y. & Olivieri, I. 1996 Local adaptation and gene-for-gene coevolution in a metapopulation model. *Proc. R. Soc. Lond. B* **263**, 1003–1009.
- Garr, S. S., Hughes, C., Welch, J., Brown, S. A. & Perlin, M. H. 1997 Correlation of haplotypes of fungal plant pathogens with their respective host species of origin. *Plant Dis.* **81**, 936–947.
- Gasner, N., Rondelaud, D., Abrous, D., Carreras, M., Boulard, F., Diez-Banos, C. & Cabaret, J. 2000 Allopatric combination of *Fasciola hepatica* and *Lymnaea trunculata* is more efficient than sympatric ones. *Int. J. Parasitol.* **30**, 573–578.
- Goldberg, D. E., Rajaniemi, T., Gurevitch, J. & Stewart-Oaten, A. 1999 Empirical approaches to quantifying interaction intensity: competition and facilitation along productivity gradients. *Ecology* **80**, 1118–1131.
- Gomulkiewicz, R., Thompson, J. N., Holt, R. D., Nuismer, S. L. & Hochberg, E. 2000 Hot spots, cold spots, and the geographic mosaic theory of coevolution. *Am. Nat.* **156**, 156–174.
- Gurevitch, J. & Hedges, L. V. 1999 Statistical issues in ecological meta-analyses. *Ecology* **80**, 1142–1149.
- Hamilton, W. D., Axelrod, R. & Tanese, R. 1990 Sexual reproduction as an adaptation to resist parasites (a review). *Proc. Natl Acad. Sci. USA* **87**, 3566–3573.
- Hanks, L. M. & Denno, R. F. 1994 Local adaptation in the armoured scale insect *Pseudaulacaspis pentagona* (Homoptera: Diaspididae). *Ecology* **75**, 2301–2310.
- Hedges, L. V. & Olkin, I. 1985 *Statistical methods for meta-analysis*. Orlando, FL: Academic Press.
- Hufbauer, R. A. & Via, S. 1999 Evolution of an aphid–parasitoid interaction: variation in resistance to parasitism among aphid populations specialized on different plants. *Evolution* **53**, 1435–1445.
- Imhoof, B. & Schmid-Hempel, P. 1998 Patterns of local adaptation of a protozoan parasite to its bumble-bee host. *Oikos* **82**, 59–65.
- Kaltz, O. & Shykoff, J. A. 1998 Local adaptation in host–parasite systems. *Heredity* **81**, 361–370.
- Kaltz, O., Gandon, S., Michalakis, Y. & Shykoff, J. A. 1999 Local maladaptation in the anther-smut fungus *Microbotryum violaceum* to its host plant *Silene latifolia*: Evidence from a cross-inoculation experiment. *Evolution* **53**, 395–407.
- Karban, R. 1989 Fine-scale adaptation of herbivorous thrips to individual hot plants. *Nature* **340**, 60–61.
- Kimberling, D. N. & Price, P. W. 1996 Variability in grape phylloxera preference and performance on canyon grape (*Vitis arizonica*). *Oecologia* **107**, 553–559.
- Koskela, T., Salonen, V. & Mutikainen, P. 2000 Local adaptation of a holoparasitic plant, *Cuscuta europaea*: variation among populations. *J. Evol. Biol.* **13**, 749–755.
- Kraaijeveld, A. R. & Godfray, H. C. J. 2001 Is there local adaptation in *Drosophila*–parasitoid interactions? *Evol. Ecol. Res.* **3**, 107–116.
- Lively, C. M. 1989 Adaptation by a parasitic trematode to local populations of its snail host. *Evolution* **43**, 1663–1671.
- Lively, C. M. 1999 Migration, virulence, and the geographic mosaic of adaptation by parasites. *Am. Nat.* **153**, S34–S47.
- Lord, F. M. 1980 *Applications of item response theory to practical testing problems*. Hillsdale, NJ: Lawrence Erlbaum Associates.
- Memmott, J., Day, R. K. & Godfray, H. C. 1995 Intraspecific variation in host plant quality: the aphid *Cinara cupressi* on the Mexican cypress *Cupressus lusitanica*. *Ecol. Entomol.* **20**, 153–158.
- Milanowski, D. J. & Bach, C. E. 1994 Between-site variation in suitability of *Salix cardata* as a host for *Altica subplicata* (Coleoptera: Chrysomelidae). *Great Lakes Entomol.* **26**, 253–261.
- Mopper, S. & Strauss, S. Y. 1998 *Genetic structure and local adaptation in natural insect populations*. New York: Chapman & Hall.
- Mopper, S., Beck, M., Simberloff, D. & Stiling, P. 1995 Local adaptation and agents of selection in a mobile insect. *Evolution* **49**, 810–815.
- Morand, S., Manning, S. D. & Woolhouse, M. E. J. 1996 Parasite–host coevolution and geographic patterns of parasite infectivity and host susceptibility. *Proc. R. Soc. Lond. B* **263**, 119–128.
- Mutikainen, P., Salonen, V., Puustinen, S. & Koskela, T. 2000 Local adaptation, resistance, and virulence in a hemiparasitic plant–host plant interaction. *Evolution* **54**, 433–440.
- Nuismer, S. L., Thompson, J. N. & Gomulkiewicz, R. 1999 Gene flow and geographically structured coevolution. *Proc. R. Soc. Lond. B* **266**, 605–609. (DOI 10.1098/rspb.1999.0679.)
- Oppliger, A., Vernet, R. & Baez, M. 1999 Parasite local maladaptation in the Canarian lizard *Gallotia galloti* (Reptilia: Lacertidae) parasitized by haemogregarian blood parasite. *J. Evol. Biol.* **12**, 951–955.
- Osenberg, C. W., Sarnelle, O., Cooper, S. D. & Holt, R. D. 1999 Resolving ecological questions through meta-analysis: goals, metrics and models. *Ecology* **88**, 1105–1117.
- Pantelouris, E. M. 1965 *The common liver fluke, Fasciola hepatica* L. Oxford: Pergamon.
- Parker, M. A. 1985 Local population differentiation for compatibility in an annual legume and its host-specific fungal pathogen. *Evolution* **39**, 713–723.
- Parker, M. A. 1989 Disease impact and local genetic diversity in the clonal plant *Podophyllum peltatum*. *Evolution* **45**, 1209–1217.
- Poulin, R. 1996 Sexual inequalities in helminth infection: a cost of being male? *Am. Nat.* **147**, 287–295.
- Powell, W. & Wright, A. F. 1988 The abilities of the aphid parasitoids *Aphidius ervi* Haliday and *A. rhopalosiphii* De Stefani Perez (Hymenoptera: Braconidae) to transfer between different known host species and the implications for the use of alternate host pests in control techniques. *Bull. Entomol. Res.* **78**, 683–693.
- Schalk, G. & Forbes, M. R. 1997 Male biases in parasitism of mammals: effects of study type, host age, and parasite taxon. *Oikos* **78**, 67–74.
- Soler, M. & Møller, A. P. 1990 Duration of sympatry and

- coevolution between the great spotted cuckoo and its magpie host. *Nature* **343**, 748–750.
- Stiling, P. & Rossi, A. M. 1998 Deme formation in a dispersive gall-forming midge. In *Genetic structure and local adaptation in natural insect populations* (ed. S. Mopper & S. Y. Strauss), pp. 22–36. New York: Chapman & Hall.
- Stiling, P., Rossi, A. M., Cattell, M. & Bowdish, T. L. 1999 Weak competition between coastal insect herbivores. *Florida Entomol.* **82**, 599–608.
- Strauss, S. Y. 1997 Lack of evidence for local adaptation to individual plants clones or site by a mobile specialist herbivore. *Oecologia* **110**, 77–85.
- Thompson, J. N. 1994 *The coevolutionary process*. University of Chicago Press.
- Tripet, F. & Richner, H. 1997 The coevolutionary potential of a ‘generalist’ parasite, the hen flea *Ceratophyllus gallinae*. *Parasitology* **115**, 419–427.
- Unruh, T. R. & Luck, R. F. 1987 Deme formation in scale insects: a test with the pinyon needle scale and a review of other evidence. *Ecol. Entomol.* **12**, 439–449.
- van der Linden, W. J. & Hambleton, R. K. 1997 *Handbook of modern item response theory*. New York: Springer.
- Van Zandt, P. A. & Mopper, S. 1998 A meta-analysis of adaptive deme formation in phytophagous insect populations. *Am. Nat.* **152**, 595–604.
- Via, S. 1991 The genetic structure of host plant adaptation in a spatial patchwork: demographic variability among reciprocally transplanted pea aphid clones. *Evolution* **45**, 827–852.
- Wainhouse, D. & Howell, R. S. 1983 Intraspecific variation in beech scale populations and in susceptibility of their host *Fagus sylvatica*. *Ecol. Entomol.* **8**, 351–359.

As this paper exceeds the maximum length normally permitted, the authors have agreed to contribute to production costs.